

## Type SHF

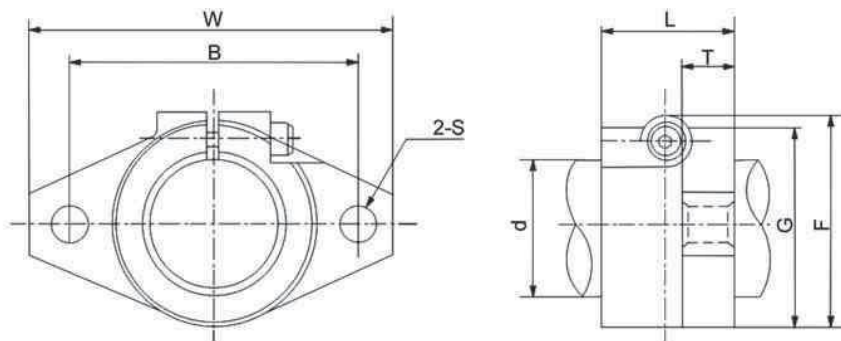

Support aluminium



Référence Type	Dimensions - mm								Vis de serrage M
	Ø d	W	L	T	F	G	B	S	
SHF4	4	43	10	5	24	20	32	5,5	M4
SHF5	5	43	10	5	24	20	32	5,5	M4
SHF6	6	43	10	5	24	20	32	5,5	M4
SHF8	8	43	10	5	24	20	32	5,5	M4
SHF10	10	43	10	5	24	20	32	5,5	M4
SHF12	12	47	13	7	28	25	36	5,5	M4
SHF13	13	47	13	7	28	25	36	5,5	M4
SHF16	16	50	16	8	31	28	40	5,5	M4
SHF20	20	60	20	8	37	34	48	7	M5
SHF25	25	70	25	10	42	40	56	7	M6
SHF30	30	80	30	12	50	46	64	9	M6
SHF35	35	92	35	14	58	50	72	12	M8
SHF40	40	102	40	16	67	56	80	12	M10
SHF50	50	122	50	19	83	70	96	14	M12
SHF60	60	140	60	23	95	82	112	14	M12

## Type SFWR



Support aluminium

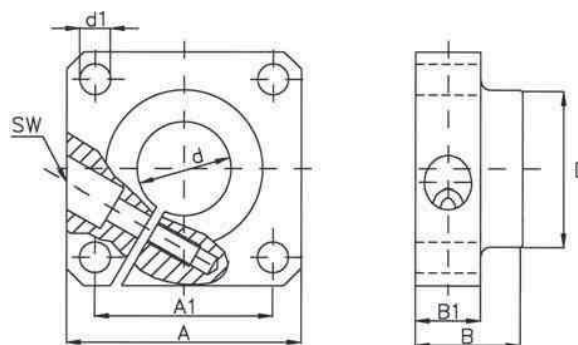

Référence Type	Dimensions - mm								Poids - Weight
	Ø d	A	B	D	A1	d1	B1	SW	g
SFWR12	12	40	20	23,5	30 ±0,12	5,5	12	3	60
SFWR16	16	50	20	27,5	35 ±0,12	5,5	12	3	80
SFWR20	20	50	23	33,5	38 ±0,12	6,6	14	4	100
SFWR25	25	60	25	42	42 ±0,12	6,6	16	5	150
SFWR30	30	70	30	49,5	54 ±0,12	9	19	6	300
SFWR40	40	100	40	65	68 ±0,12	11	26	8	700
SFWR50	50	100	50	75	75 ±0,12	11	36	8	1 200

Type FGWN/FGWH

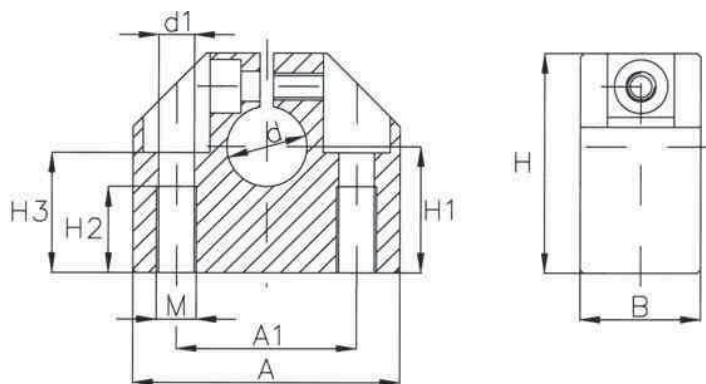

Support aluminium

Référence Type	Dimensions - mm										Poids - Weight
	Ø d	A ±0,12	B	H	H1 ±0,1	A1	d1	M	H2	H3	g
FGWN12	12	43	20	35	20	30	5,2	M6	13	16,5	100
FGWN16	16	53	24	42	25	38	6,8	M8	18	21	150
FGWN20	20	60	30	50	30	42	8,6	M10	22	25	230
FGWN25	25	78	38	60	35	56	10,3	M12	26	30	410
FGWN30	30	87	40	70	40	64	10,3	M12	26	34	530
FGWN40	40	108	48	90	50	82	14,25	M16	34	44	990
FGWN50	50	132	58	105	60	100	17,5	M20	43	49	1 250

Référence Type	Dimensions - mm										Poids - Weight
	Ø d	A ±0,12	B	H	H1 ±0,1	A1	d1	M	H2	H3	g
FGWH6	6	32	16	27	15	22	4,2	M5	11	13	30
FGWH8	8	32	16	27	16	22	4,2	M5	11	13	30
FGWH10	10	40	18	33	18	27	5,2	M6	13	16	50
FGWH12	12	40	18	33	19	27	5,2	M6	13	16	50
FGWH14	14	45	20	38	20	32	5,2	M6	13	18	70
FGWH16	16	45	20	38	22	32	5,2	M6	13	18	70
FGWH20	20	53	24	45	25	39	6,8	M8	18	22	120
FGWH25	25	62	28	54	31	44	8,6	M10	22	26	170
FGWH30	30	67	30	60	34	49	8,6	M10	22	29	220
FGWH40	40	87	40	76	42	66	10,3	M12	26	38	480
FGWH50	50	103	50	92	50	80	14,25	M16	34	46	820

Type FGWA



Support aluminium

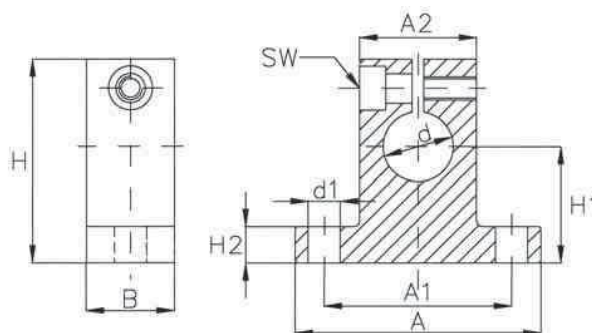

Référence Type	Dimensions - mm ( $\pm 0,15$ )										Poids - Weight
	$\varnothing d$	A	B	H	H1	A1	A2	d1	SW	H2	g
FGWA10	10	37	11	30	17	28	18	5	M3	45	14
FGWA12	12	42	12	35	20	32	20	5,5	M3	5,5	26
FGWA16	16	50	16	42	25	40	28	5,5	M3	6,5	39
FGWA20	20	60	20	50	30	45	32	5,5	M4	8	78
FGWA25	25	74	25	58	35	60	38	6,6	M5	9	135
FGWA30	30	84	28	68	40	68	45	9	M6	10	200
FGWA40	40	108	32	86	50	86	56	11	M8	12	362
FGWA50	50	130	40	100	60	108	80	11	M8	14	740
FGWA60	60	160	48	124	75	132	100	13,5	M8	15	1 400
FGWA80*	80	200	60	160	100	170	130	17,5	M10	22	7 100

\* Le support FGWA80 est en fonte

\* The FGWA80 is in cast iron