

### 2.3.5 Flanged Double Nut DDB (DIN 69051 Part 5)

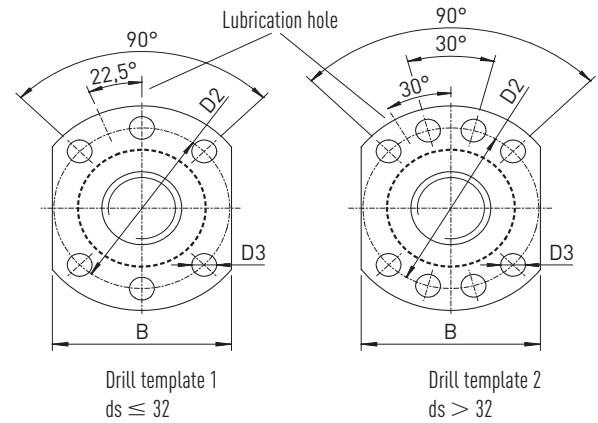
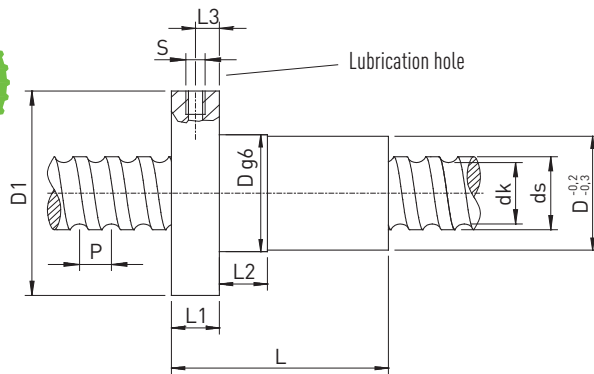

Table 2.10 Dimensions of the nut

Article number	ds h6	P	D g6	D1	D2	D3	L	L1	L2	L3	S	B	dk	Dyn. Load C <sub>dyn</sub> [N]	Stat. Load C <sub>0</sub> [N]	Mass [kg/pc.]
R16-05T3-DDB	16	5	28	48	38	5,5	80	10	10	5	M6	40	13,5	9600	12700	0,36
R20-05T4-DDB	20	5	36	58	47	6,6	82	10	10	5	M6	44	17,5	13900	21800	0,45
R25-05T4-DDB	25	5	40	62	51	6,6	95	10	10	5	M6	48	22,5	15600	27900	0,55
R25-10T3-DDB	25	10	40	62	51	6,6	115	10	16	5	M6	48	21,0	24100	36200	0,60
R32-05T5-DDB	32	5	50	80	65	9,0	95	12	10	6	M6	62	29,5	20700	43900	0,97
R32-10T4-DDB	32	10	50	80	65	9,0	138	14	16	7	M6	62	27,8	40900	63200	1,03
R32-20T2-DDB	32	20	50	80	65	9,0	138	14	16	7	M6	62	27,8	20300	26800	1,02
R40-05T5-DDB	40	5	63	93	78	9,0	109	14	10	7	M8x1	70	37,5	22500	54600	1,55
R40-10T4-DDB	40	10	63	93	78	9,0	150	14	16	7	M8x1	70	35,8	46800	82600	2,15
R40-20T2-DDB	40	20	63	93	78	9,0	150	14	16	7	M8x1	70	35,8	23800	36400	1,80
R50-05T5-DDB	50	5	75	110	93	11,0	112	16	10	8	M8x1	85	47,5	24900	69800	2,16
R50-10T4-DDB	50	10	75	110	93	11,0	164	16	16	8	M8x1	85	45,8	52800	106800	2,50
R50-20T3-DDB	50	20	75	110	93	11,0	196	16	16	8	M8x1	85	45,8	40000	76200	4,34
R63-10T6-DDB	63	10	90	125	108	11,0	205	18	16	9	M8x1	95	58,8	84700	210800	4,40
R63-20T4-DDB	63	20	95	135	115	13,5	270	20	25	10	M8x1	100	55,4	105000	250000	6,95
R80-10T6-DDB	80	10	105	145	125	13,5	205	20	16	10	M8x1	110	75,8	93400	269200	4,75
R80-20T4-DDB	80	20	125	165	145	13,5	280	25	25	12	M8x1	130	72,4	135000	322000	13,85

- Reduced axial play on request
- DIN nuts for peeled ballscrew spindles
- Mating dimensions to DIN 69051 Part 5
- Nuts with dust wipers
- Precision ground ball grooves
- Left-hand nuts on request
- Nut-housing (page 111)

Order example: **R** **63** **10** **T6** **DDB** **3850** **3972** **0,052**